

X-Pruf® Solids Handling Submersible Pumps

Specifications:

DISCHARGE	3", 125 lb. Horizontal Flange Slotted to accommodate 80mm ISO Flanges
LIQUID TEMPERATURE	104°F (40°C) Continuous
VOLUTE	Cast Iron ASTM A-48, Class 30
WEAR RING	C954 Lead-Free Bronze
MOTOR HOUSING	Cast Iron ASTM A-48, Class 30
SEAL PLATE	Cast Iron ASTM A-48, Class 30
IMPELLER:	
<i>Design</i>	Enclosed Monovane, With Pump Out Vaness on Back Side. Dynamically Balanced ISO G6.3
<i>Material</i>	Ductile Iron ASTM A-536, 65-45-12
SHAFT	416 Stainless Steel
"O" RINGS	Buna-N
HARDWARE	300 Series Stainless Steel
LIFTING BAIL	300 Series Stainless Steel
PAINT	Epoxy Dupont Corlar® Amine Epoxy, Two Coats
SEAL:	
<i>Design</i>	Tandem Mechanical, Oil Filled Reservoir.
<i>Material: Inboard</i>	Rotating Faces - Carbon Stationary Faces - Ceramic
<i>Material: Outboard</i> ...	Rotating Faces - Silicon Carbide Stationary Faces - Silicon Carbide Elastomer - Buna-N Hardware - 300 Series Stainless
CORD ENTRY	Custom Molded, Quick Connected for Sealing and Strain Relief
POWER CORD	CSA Certified Submersible Power Cable 2000V - Ordered Separately
SPEED	1750 RPM (Nominal)
UPPER BEARING:	
<i>Design</i>	Single Row, Ball, Oil Lubricated
<i>Load</i>	Radial
LOWER BEARING:	
<i>Design</i>	Double Row, Ball, Oil Lubricated
<i>Load</i>	Radial & Thrust
MOTOR:	
<i>Design</i>	NEMA B - Three Phase Torque Curve NEMA L - Single Phase Torque Curve Oil-Filled, Squirrel Cage Induction, Inverter Duty rated per NEMA MG1
<i>Insulation</i>	Class H Varnish & Magnet Wire
SINGLE PHASE	Requires overload protection to be included in control panel. Requires start components to be included in panel. Provided with pump.
THREE PHASE	Requires overload protection to be included in control panel.
MOISTURE SENSOR	Normally Open (N/O), Requires Relay in Control Panel
TEMPERATURE SENSOR	Three Normally Closed (N/C). To be wired in series with control circuit.
OPTIONAL EQUIPMENT	White Iron Impeller, Seal Material, Impeller Trims, Cord Length
MARKINGS	CSA, CE
WEIGHT	220 lbs (100 Kg)
NOISE EMISSION MAX	In-Air 65 dB-A
SUBMERGENCE	Max Depth 66ft (20m)
RECOMMENDED:	
<i>Accessories</i>	Break Away Fitting (BAF) Check Valve Control Panel Leg Kit

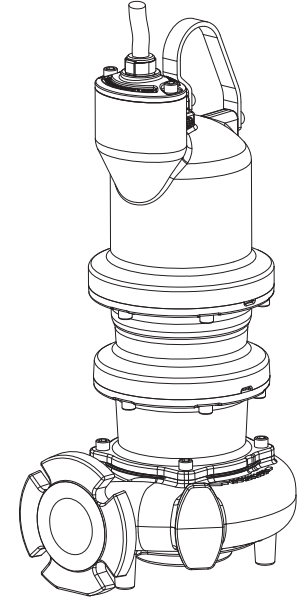

Series: 3XSHM 3 - 7.5HP, 1750RPM, 60Hz

Explosion Proof, Class I, Division 1, Groups C & D, T4

Sample Specifications: Section 0.1B Page G.

This product may be covered by one or more of the
following patents and other patent(s) pending:
US Patent 7,931,473

DESCRIPTION:

SUBMERSIBLE NON-CLOG PUMP
DESIGNED FOR RAW SEWAGE
APPLICATIONS.



WARNING:
CANCER AND REPRODUCTIVE HARM -
WWW.P65WARNINGS.CA.GOV



LR16567



X-Pruf® Solids Handling Submersible Pumps

3XSHMPA Pump - 18 Frame Driver

inches
(mm)

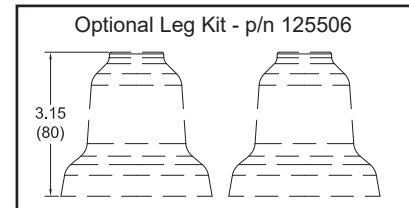
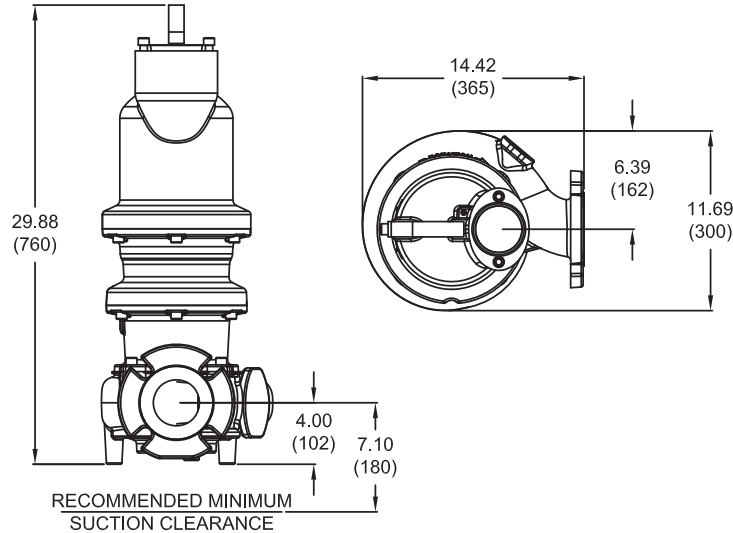

IMPORTANT !

- 1.) MOISTURE AND TEMPERATURE SENSORS MUST BE CONNECTED TO VALIDATE THE CSA LISTING.
- 2.) A SPECIAL MOISTURE SENSOR RELAY IS REQUIRED IN THE CONTROL PANEL FOR PROPER OPERATION OF THE MOISTURE SENSORS. CONTACT BARNES PUMPS FOR INFORMATION CONCERNING MOISTURE SENSING RELAYS FOR CUSTOMER SUPPLIED CONTROL PANELS.
- 3.) THESE PUMPS ARE CSA LISTED FOR PUMPING WATER AND WASTEWATER. **DO NOT USE TO PUMP FLAMMABLE LIQUIDS.** NOT SUITABLE FOR ENVIRONMENTS CONTAINING GASOLINE OR HEXANE.
- 4.) INSTALLATIONS SUCH AS DECORATIVE FOUNTAINS OR WATER FEATURES PROVIDED FOR VISUAL ENJOYMENT MUST BE INSTALLED IN ACCORDANCE WITH THE NATIONAL ELECTRIC CODE ANSI/NFPA 70 AND/OR THE AUTHORITY HAVING JURISDICTION. THIS PUMP IS NOT INTENDED FOR USE IN SWIMMING POOLS, RECREATIONAL WATER PARKS, OR INSTALLATIONS IN WHICH HUMAN CONTACT WITH PUMPED MEDIA IS A COMMON OCCURRENCE.

X-Pruf® Solids Handling Submersible Pumps

MODEL NO	HP	VOLT	PH	Hz	RPM (Nom)	NEMA START CODE	FULL LOAD AMPS	SERVICE FACTOR	SERVICE FACTOR AMPS	LOCKED ROTOR AMPS	DRIVER FRAME	CORD P/N ▲	CORD SIZE
3XSHMPA3074	3	208	1	60	1750	D	14.9	1.2	18.5	59.1	18	125496	12/4 - 18/4
		230				14.1	1.2	16.5	66.3				
3XSHMPA30N4	3	208	3	60	1750	K	9.7	1.2	11.4	58.2 /	18	125496	12/4 - 18/4
		230					1.2	10.6	65.8				
		460					1.2	5.3	32.9				
3XSHMPA3054	3	575	3	60	1750	N	4.5	1.2	4.9	37.0	18	125497	12/4 - 18/4
3XSHMPA5074	5	208	1	60	1750	D	27.2	1.2	35.6	99.9	18	125498	8/4 - 18/4
		230				25.4	1.2	30.2	112.4				
3XSHMPA50N4	5	208	3	60	1750	J	15.8	1.2	18.7	82.4 /	18	125496	12/4 - 18/4
		230					1.2	17.2	92.4				
		460					1.2	8.6	46.2				
3XSHMPA5054	5	575	3	60	1750	J	6.0	1.2	6.9	37.0	18	125497	12/4 - 18/4
3XSHMPA75N4	7.5	208	3	60	1750	H	23.8	1.2	28.5	105.9 /	18	125496	12/4 - 18/4
		230					1.2	27.2	123.6				
		460					1.2	13.6	61.8				
3XSHMPA7554	7.5	575	3	60	1750	H	9.5	1.2	10.9	49.4	18	125497	12/4 - 18/4

3XSHMPA Pump

IMPORTANT !

Moisture and Temperature sensor leads are integral to power cord. Pump rated for operation at ± 10% voltage at motor.

▲ Cord Suffix: XC - 30 Feet, XF - 50 Feet, XJ - 75 Feet, or XL - 100 Feet.

▲ Cord sold separately.

Series 3XSHM

Performance Curve
3 - 7.5HP, 1750RPM, 60Hz

BARNES®

www.cranepumps.com

X-Pruf® Solids Handling Submersible Pumps

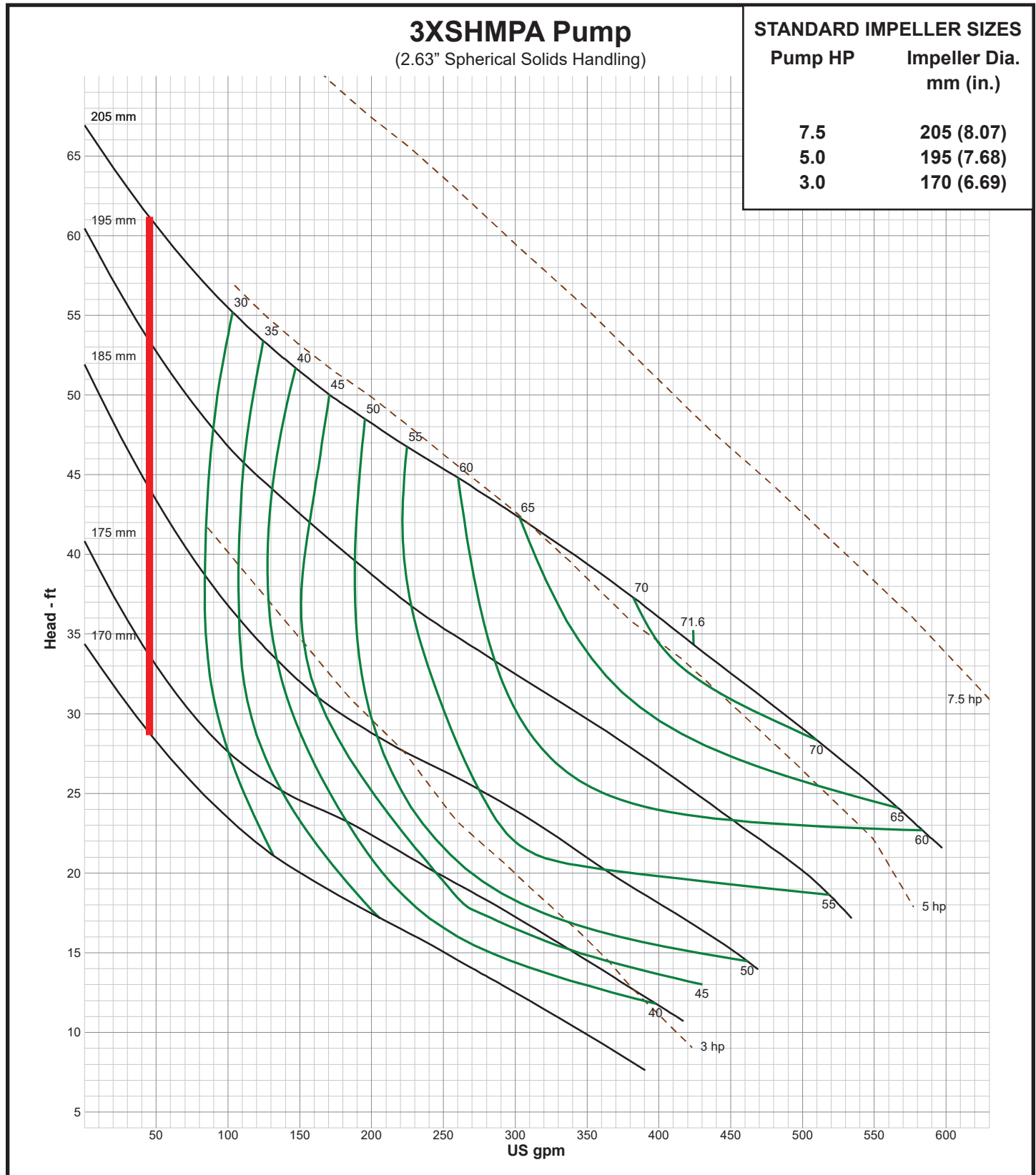

SECTION 0.1B
PAGE 20
DATE 2/20

CRANE
A Crane Co. Company

PUMPS & SYSTEMS

USA: (937) 778-8947 • Canada: (905) 457-6223 • International: (937) 615-3598