

BARNES®

INSTALLATION and OPERATION MANUAL Submersible Grinder Pump

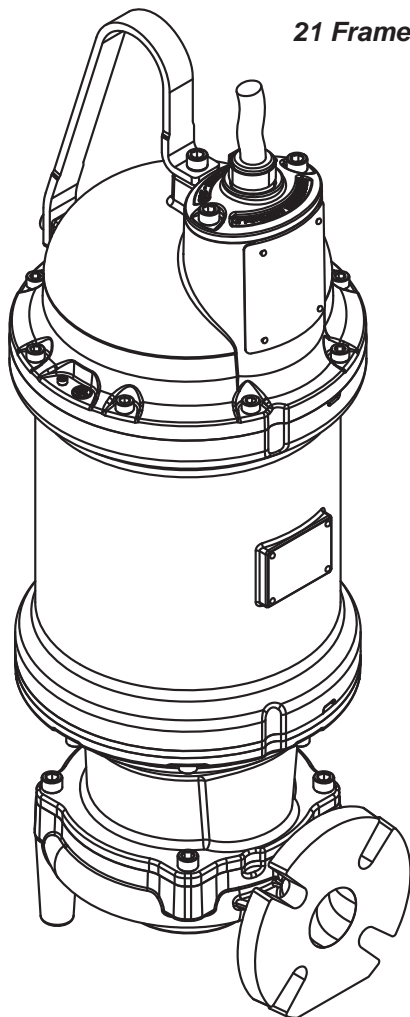

Explosion Proof, Class 1,
Division 1, Groups C & D, T4

BLADE XGVHH
Horizontal Discharge Pumps
7.5 - 15HP, 3450RPM

This product may be covered by one
or more of the following patents and
other patent(s) pending:
US Patent 7, 931, 473

IMPORTANT!

Read all instructions in this manual before operating pump.

As a result of Crane Pumps & Systems, Inc., constant product improvement program, product changes may occur. As such Crane Pumps & Systems reserves the right to change product without prior written notification.

CRANE

A Crane Co. Company

PUMPS & SYSTEMS

420 Third Street
Piqua, Ohio 45356
Phone: (937) 778-8947
Fax: (937) 773-7157
www.cranepumps.com

83 West Drive, Brampton
Ontario, Canada L6T 2J6
Phone: (905) 457-6223
Fax: (905) 457-2650



Form No. 141183-Rev. A

TABLE OF CONTENTS

SAFETY FIRST	3
A. GENERAL INFORMATION.....	5
B. INSTALLATION.....	5 - 13
ELECTRICAL DATA.....	6 - 13
C. START-UP OPERATION	10 - 11
D. PREVENTATIVE MAINTENANCE.....	11
E. SERVICE and REPAIR.....	11 - 12
F. REPLACEMENT PARTS	13
TROUBLESHOOTING.....	14
BLADE XGVHH - CROSS-SECTIONS, (Fig. 9) & EXPLODED VIEWS, (Fig. 10)	15 - 16
PARTS LISTS	17 - 18
WARRANTY	19
RETURNED GOODS POLICY	20
WARRANTY REGISTRATION.....	20
START-UP REPORT	21 - 22

Other brand and product names are trademarks or registered trademarks of their respective holders.

© Barnes is a registered trademark of Crane Pumps & Systems, Inc
1995,1997,1998,1/2004, 4/05, 1/06, 3/06, 9/06, 12/06, 2/07

Alteration Rights Reserved

SAFETY FIRST!

Please Read This Before Installing Or Operating Pump.
This information is provided for **SAFETY and to PREVENT EQUIPMENT PROBLEMS**. To help recognize this information, observe the following symbols:



IMPORTANT! Warns about hazards that can result in personal injury or Indicates factors concerned with assembly, installation, operation, or maintenance which could result in damage to the machine or equipment if ignored.

CAUTION ! Warns about hazards that can or will cause minor personal injury or property damage if ignored. Used with symbols below.

WARNING ! Warns about hazards that can or will cause serious personal injury, death, or major property damage if ignored. Used with symbols below.



Hazardous fluids can cause fire or explosions, burns or death could result.



Extremely hot - Severe burns can occur on contact.



Biohazard can cause serious personal injury.



Hazardous fluids can cause pressure, eruptions or explosions could cause personal injury or property damage.



Rotating machinery Amputation or severe laceration can result.



Hazardous voltage can shock, burn or cause death.

Only qualified personnel should install, operate and repair pump. Any wiring of pumps should be performed by a qualified electrician.



WARNING ! - To reduce risk of electrical shock, pumps and control panels must be properly grounded in accordance with the National Electric Code (NEC) or the Canadian Electrical Code (CEC) and all applicable state, province, local codes and ordinances.

WARNING! - To reduce risk of electrical shock, always disconnect the pump from the power source before handling or servicing. Lock out power and tag.



WARNING! Operation against a closed discharge valve will cause premature bearing and seal failure on any pump, and on end suction and

self priming pump the heat build may cause the generation of steam with resulting dangerous pressures. It is recommended that a high case temperature switch or pressure relief valve be installed on the pump body.



CAUTION ! Never operate a pump with a plug-in type power cord without a ground fault circuit interrupter.



CAUTION! Pumps build up heat and pressure during operation-allow time for pumps to cool before handling or servicing.



WARNING! - **DO NOT** pump hazardous materials (flammable, caustic, etc.) unless the pump is specifically designed and designated to handle them.



Do not block or restrict discharge hose, as discharge hose may whip under pressure.



WARNING! - DO NOT wear loose clothing that may become entangled in the impeller or other moving parts.



WARNING! - Keep clear of suction and discharge openings. **DO NOT** insert fingers in pump with power connected.



Always wear eye protection when working on pumps.



Make sure lifting handles are securely fastened each time before lifting. **DO NOT** operate pump without safety devices in place. Always replace safety devices that have been removed during service or repair. Secure the pump in its operating position so it can not tip over, fall or slide.



DO NOT exceed manufacturers recommendation for maximum performance, as this could cause the motor to overheat.

DO NOT remove cord and strain relief. Do not connect conduit to pump.



WARNING! Cable should be protected at all times to avoid punctures, cut, bruises and abrasions - inspect frequently. Never handle connected power cords with wet hands.



WARNING! To reduce risk of electrical shock, all wiring and junction connections should be made per the NEC or CEC and applicable state or province and local codes. Requirements may vary depending on usage and location.

WARNING! Submersible Pumps are not approved for use in swimming pools, recreational water installations, decorative fountains or any installation where human contact with the pumped fluid is common.



WARNING! Products Returned Must Be Cleaned, Sanitized, Or Decontaminated As Necessary Prior To Shipment, To Insure That Employees Will Not Be Exposed To Health Hazards In Handling Said Material. All Applicable Laws And Regulations Shall Apply.



Bronze/brass and bronze/brass fitted pumps may contain lead levels higher than considered safe for potable water systems. Lead is known to cause cancer and birth defects or other reproductive harm. Various government agencies have determined that leaded copper alloys should not be used in potable water applications. For non-leaded copper alloy materials of construction, please contact factory.



IMPORTANT! - Crane Pumps & Systems, Inc. is not responsible for losses, injury, or death resulting from a failure to observe these safety precautions, misuse or abuse of pumps or equipment.

USER GUIDE

USER GUIDE

Congratulations on your purchase of a Barnes *UltraGRIND™* grinder pump system. With proper care and by following a few simple guidelines your grinder pump will give you many years of dependable service.

Use and Care

The *UltraGRIND* grinder pump station is designed to handle routine, domestic sewage. Solid waste materials should be thrown in the trash. While your station is capable of accepting and pumping a wide range of materials, regulatory agencies advise that the following items should not be introduced into any sewer either directly or through a kitchen waste disposal:

- Glass
- Metal
- Diapers
- Socks, rags or cloth
- Plastic objects (e.g., toys, utensils, etc.)
- Sanitary napkins or tampons

In addition you must **NEVER** introduce into any sewer:

- Explosives
- Flammable Material
- Lubricating Oil and/or Grease
- Strong Chemicals
- Gasoline

General Information

Your home wastewater disposal service is part of a low pressure sewer system. The key element in this system is the Barnes *UltraGRIND* grinder pump station. The basin collects all wastewater from the house. The solids in the sewage are then ground to a small size suitable for pumping in the slurry.

The grinder pump generates sufficient pressure to pump this slurry from your home to the wastewater plant.

Power Failure

Your grinder pump cannot dispose of wastewater or provide an alarm signal without electrical power. If electrical power service is interrupted, keep water usage to a minimum.

Warranty

Your grinder pump is furnished with a warranty against defects in material or workmanship. A properly completed Start-Up/Warranty Registration form must be on file at the Barnes factory in order to activate your warranty. In addition your pump must be installed in accordance with the installation instructions.

If you have a claim under the provisions of the warranty, contact your local Barnes Distributor. When contacting your representative for service, please include your station serial number, pump model number, and pump serial number.

For future reference, record the following information:

Station Serial No: _____

Pump Model No: _____

Pump Serial No: _____

Local Distributor: _____

Distributor Telephone: _____

SECTION A: GENERAL INFORMATION

A-1) To the Purchaser:

Congratulations! You are the owner of one of the finest pumps on the market today. CP&S pumps are products engineered and manufactured of high quality components. Over one hundred years of pump building experience along with a continuing quality assurance program combine to produce a pump which will stand up to the toughest applications. This manual will provide helpful information concerning installation, maintenance, and proper service guidelines.

A-2) Receiving:

Upon receiving the pump, it should be inspected for damage or shortages. If damage has occurred, file a claim immediately with the company that delivered the pump. **MAKE CERTAIN TO RETAIN THIS MANUAL!**

A-3) Storage:

Short Term- CP&S Pumps are manufactured for efficient performance following short inoperative periods in storage. For best results, pumps can be retained in storage, as factory assembled, in a dry atmosphere with constant temperatures for up to six (6) months.

Long Term - Any length of time exceeding six (6) months, but not more than twenty-four (24) months. The unit should be stored in a temperature controlled area, a roofed over walled enclosure that provides protection from the elements (rain, snow, wind-blown dust, etc.), and whose temperature can be maintained between +40 deg. F and +120 deg. F. (4.4 - 49°C). Pump should be stored in its original shipping container. On initial start up, rotate impeller by hand to assure seal and impeller rotate freely. If it is required that the pump be installed and tested before the long term storage begins, such installation will be allowed provided:

- 1.) The pump is not installed under water for more than one (1) month.
- 2.) Immediately upon satisfactory completion of the test, the pump is removed, thoroughly dried, repacked in the original shipping container, and placed in a temperature controlled storage area.

A-4) Service Centers:

For the location of the nearest Barnes Service Center, check your Barnes representative or Crane Pumps & Systems, Inc., Service Department in Piqua, Ohio, telephone (937) 778-8947 or Crane Pumps & Systems Canada, in Brampton, Ontario, (905) 457-6223.

SECTION B: INSTALLATION

B-1) Location:

These self-contained pumping units have motors that are Underwriters Laboratory Listed for Class 1, Groups C & D, Division 1 locations and are recommended for use in a sump, lift stations or basin. This pump is designed for submerged continuous duty (15 minutes duty in air at nameplate horsepower), pumping sewage, effluent, wastewater or other non explosive or non corrosive liquids not above 104°F (40°C), never install the pump in a trench, ditch or hole with a dirt bottom; the legs will sink into the dirt and the suction will become plugged.

B-1.1) Submergence:

It is recommended that the pump be operated in the Continuous Duty Submergence condition and the sump liquid level should never be less than the Minimum Submergence Level (See Fig. 1). The time required to draw the well down from top of motor to the minimum submergence level should not be greater than 15 minutes.

NOTE: Outer shaft seal must be in liquid when motor is operated, whether motor is submerged or in air.

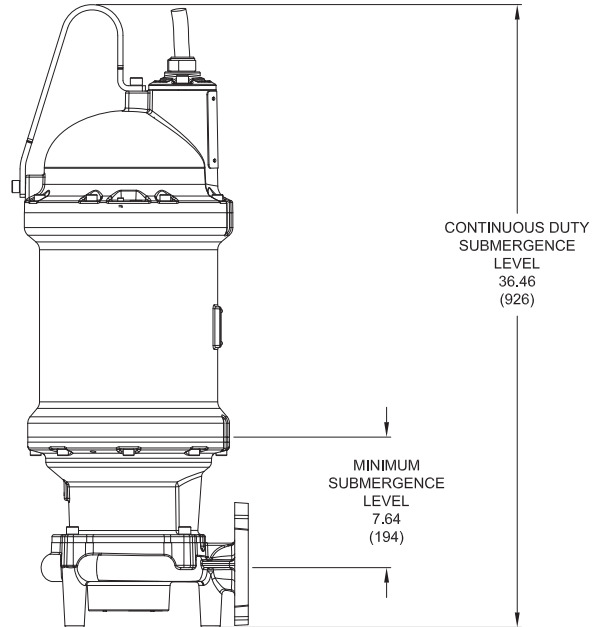

FIGURE 1

B-2) Discharge:

Discharge piping should be as short as possible. Both a check valve and a shut-off valve are recommended for each pump being used. The check valve is used to prevent backflow into the sump. Excessive backflow can cause flooding and/or damage to the pump. The shut-off valve is used to stop system flow during pump or check valve servicing.

WARNING! These pumps are suitable for application in Class 1, Division 1, Groups C & D, HAZARDOUS LOCATIONS and require a non-sparking break away fitting. Failure to use the non-sparking BAF voids warranty.

Barnes Pumps manufactures a break away fitting discharge system designed to allow the submersible wastewater pump to be installed or removed without requiring personnel to enter the wet well. Place the Break Away Fitting (BAF) in position. Temporarily secure the guide rails in the upper mounting brackets and locate the base elbow on the bottom of the wet well. Level the base elbow with grout and/or shims. Install the intermediate support brackets, if required. Make sure the rails are in a true vertical position so the pump will clear the access opening and will slide freely down the rails into place on the discharge base elbow. Once the rails are in proper alignment, bolt the base elbow into the floor of the station and connect the discharge pipe to

the elbow. Connect the movable portion and other supplied fittings of the BAF onto the pump and lower into wet well. See the Break Away Fitting manual for more information.



WARNING! Level control used within the hazardous location, must be in an intrinsically safe control circuit suitable for use in Class 1, Division 1, Groups C & D, Hazardous Locations.

B-3) Liquid Level Controls:

It is recommended to use a liquid level control system that allows the on and off point to be separated by at least twelve inches. An additional set point (lag point) should be incorporated with an alternator switching system for a duplex (two pump) station. A high level alarm may be required to alert maintenance personnel that there is a high water situation in the wet well should the output of the pump station drop below the inflow rate. A low level cut off may be installed to provide system shutdown if the main level control system malfunctions. The off point should be positioned so that the liquid level never drops below the minimum continuous duty point for the pump shown in figure 1.

B-4.1) Electrical Connections:

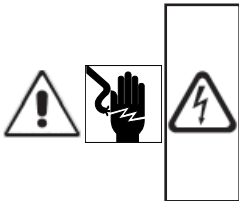

WARNING! - All model pumps and control panels must be properly grounded per the NATIONAL ELECTRIC CODE or CANADIAN ELECTRIC CODE, State, Province and local codes. Improper grounding voids warranty.

B-4) Power/Control Cord:

The power/control cord used with pump has a patent pending "quick disconnect" feature that allows the cord to be easily attached and disconnected at the pump. The maximum amperage rating for the cord is cast in the top of the cast stainless mounting plate. The voltage connection for the motor is determined by the cord assembly used. Low voltage cords (208 & 230 Volt) utilize a molded quick connect plug that is colored black. High voltage cords (460 & 575 Volt) utilize a molded quick connect cord that is colored orange. **It is important to verify that the cord being used is rated for the nameplate voltage and amperage rating shown on the pump nameplate. Refer to Chart on page 7.** No internal wiring adjustments are necessary for dual and tri-voltage pumps. All jumper connections to set the proper voltage are made by the cord plug itself.

A flat alignment mark is molded into the plug and mating socket on the pump. These should be used as a visual indication as to the correct orientation of the plug. Insert the plug into the pump and install the two 12 mm socket head cap screws into the clamping plate. Slowly tighten the two screws alternating back and forth until the clamping plate is drawn down flush to the top of the cord boss on the pump. The two screws should be torqued until the plate is down to a point where metal to metal contact is made between the stainless steel plate and pump housing. (See Figure 2)

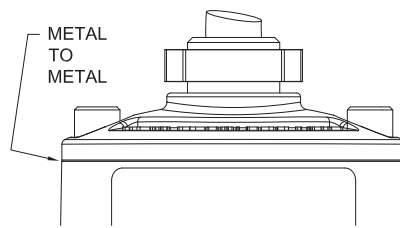

FIGURE 2a

The cord assembly mounted to the pump must not be modified in any way except for shortening to a specific application. Any splice between the pump and the control panel must be made in accordance with all applicable electric codes. It is recommended that a junction box with seal fittings (if used) be mounted outside the sump or be of at least Nema 7 explosion proof construction if located within the wet well. A listed water and vapor tight seal fitting **MUST** be used in conduit leaving the wet well to prevent moisture and gasses from reaching the control panel. Prior to installation, the pump power cable should be inspected for nicks or damage. If damaged, the cord should be replaced before installation.

DO NOT USE THE POWER CORD TO LIFT PUMP.

B-4.1) Electrical Connections:

When the electrical connections are made, the lead wires from the power cable should be stripped so that the ground wire is at least two inches longer than the power leads. This will ensure that if the cable is inadvertently pulled out of the connection point, the ground wire will be the last lead to break the circuit.

B-4.2) Wire Size:

If additional cable is required consult a qualified electrician for proper wire size. Voltage drop due to wire resistance between the pump and power connection point should be limited to 3% when additional cable is added.

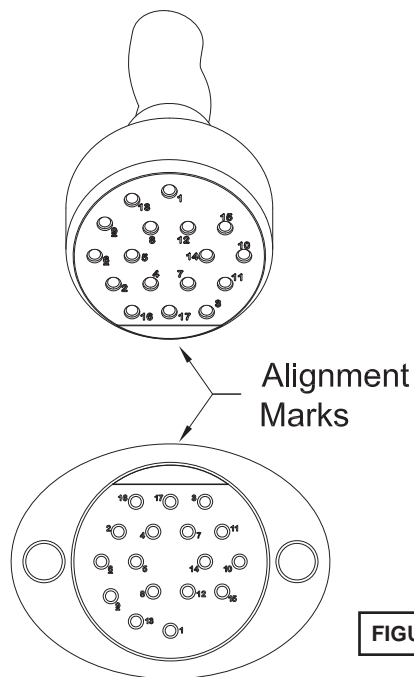

FIGURE 2b

MODEL NO	PART NO	HP	VOLT	PH	HZ	RPM (Nom)	NEMA START CODE	FULL LOAD AMPS	SERVICE FACTOR	LOCKED ROTOR AMPS	CORD P/N ▲	CORD SIZE	CORD O.D.	WINDING RESISTANCE MAIN - START
XGVHH75N2	141369	7.5	208	3	60	3450	K	38.8	1.0	195.7	125498	8/4 - 18/4	1.12 ± .02	.247
			35.1											
			17.5											
XGVHH7552	141371	7.5	575	3	60	3450	K	14.0	1.0	70.8	125497	12/4 - 18/4	.86 ± .02	1.610
XGVHH100N2	141372	10.0	208	3	60	3450	H	45.9	1.0	195.7	125498	8/4 - 18/4	1.12 ± .02	.247
			41.6											
			20.8											
XGVHH10052	141374	10.0	575	3	60	3450	H	16.6	1.0	70.8	125497	12/4 - 18/4	.86 ± .02	1.610
XGVHH150N2	141375	15.0	208	3	60	3450	E	59.0	1.0	195.7	125498	8/4 - 18/4	1.12 ± .02	.247
			57.1											
			28.5											
XGVHH15052	141377	15.0	575	3	60	3450	E	22.8	1.0	70.8	125497	12/4 - 18/4	.86 ± .02	1.610

BLADE XGVHH Pump - Horizontal

IMPORTANT !

Moisture and Temperature sensor leads are integral to power cord.
 Pump rated for operation at ± 10% voltage at motor.

▲ Cord Suffix: XC - 30 Feet, XF - 50 Feet, XJ - 75 Feet, or XL - 100 Feet.

▲ Cord sold separately.

THREE PHASE 460-575 VOLT AC (orange molded plug)	
Power Cable	Motor Lead ID
Green (Ground)	Green
Black	1
Red	2
White	3
Jumpered Inside Cord Automatically (No user jump- ering required)	T4 & T7 Together
	T5 & T8 Together
	T6 & T9 Together

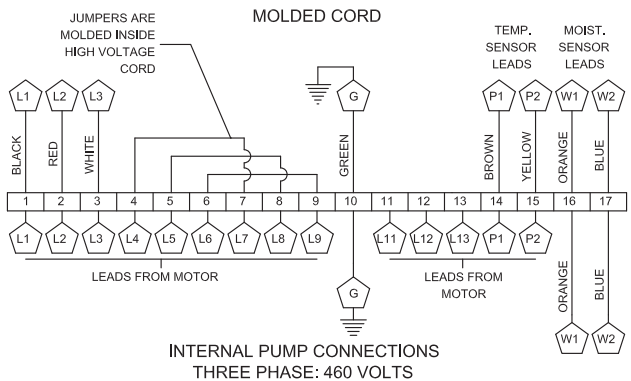

FIGURE 3a

MOISTURE AND TEMPERATURE SENSORS	
Control Cable	Lead ID
Green (Ground)	Green
Brown	P1 (Temperature Sensor)
Yellow	P2 (Temperature Sensor)
Orange	W1 (Moisture Sensor)
Blue	W2 (Moisture Sensor)

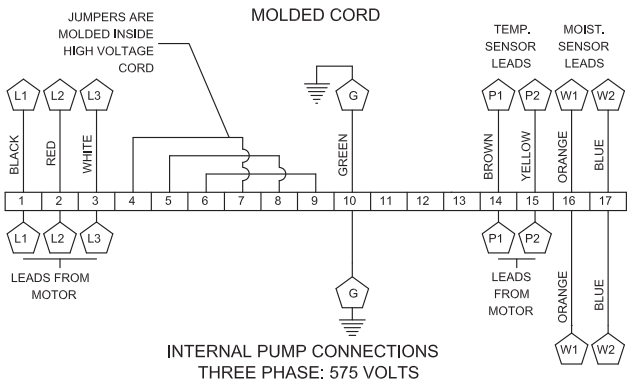

FIGURE 3c

THREE PHASE 208-230 VOLT AC (black molded plug)	
Power Cable	Motor Lead ID
Green (Ground)	Green
Black	1
Red	2
White	3
Jumpered Inside Cord Automatically (No user jump- ering required)	T4, T5 & T6 Together
	T11 & T7 Together
	T13 & T9 Together
	T12 & T8 Together

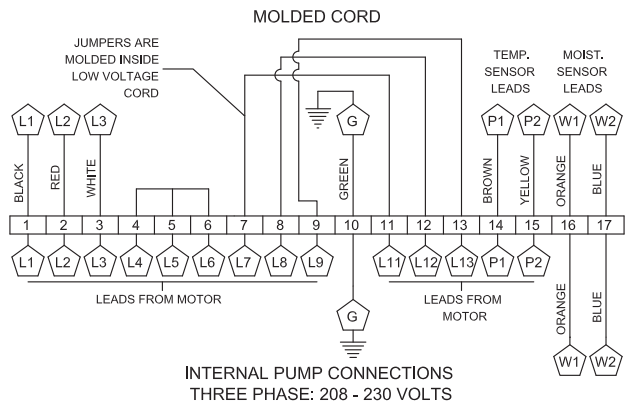

FIGURE 3b

TYPICAL POWER CIRCUIT

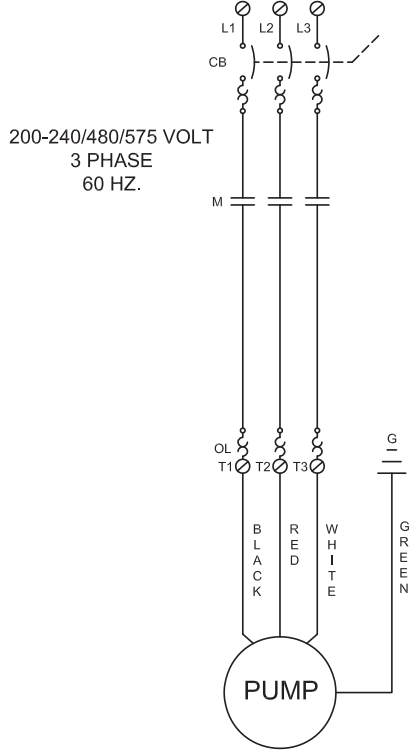

FIGURE 3d

External Ground Note:

(Grd symbol) An external ground screw is provided on the side of the motor cap which can be used for supplemental bonding connection where local codes permit or require such connection.

TYPICAL THERMAL PROTECTION WIRING DIAGRAM

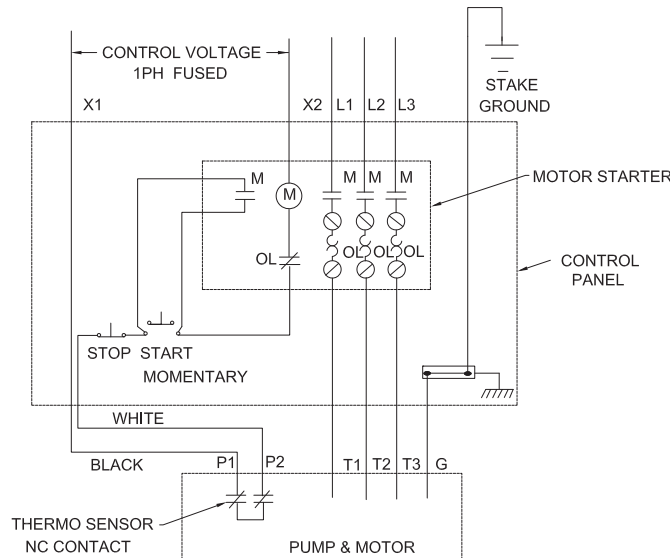

FIGURE 4



WARRANTY NOTE:

Both the temperature sensor and moisture detection system must be connected to the motor circuitry such that the motor will be de-energized or sound alarm if excessive motor temperatures are reached and/or if water is detected in the seal chamber and/or motor chamber. Failure to have the above mentioned systems installed and operative, nullifies warranty.

B-4.3) Overload Protection:

Current sensing overloads must be provided in the pump control panel and should be properly sized for the full load current of the pump. Three normally closed (N/C) thermal sensors wired in series (one per phase) are embedded in the motor windings and will detect excessive heat in the event an overload condition occurs which will then trip and stop the pump when wired in series with the pump contactor control circuit. The thermal sensor leads marked P1 and P2 **MUST** be connected in series with the stop button of the pilot circuit of the magnetic motor controller located in the control panel so that the thermostat will open the circuit before dangerous temperatures are reached. A manual momentary start switch is required to prevent the automatic restarting of the motor when the thermostat resets. For a typical wiring diagram, refer to Figure 4.

In the event of an over temperature condition, the source of this condition should be determined and rectified before the pump is put back into normal operation. **DO NOT LET THE PUMP CYCLE OR RUN IF AN OVER TEMPERATURE CONDITION OCCURS!**

If current through the temperature sensor exceeds the values listed, an intermediate control circuit relay must be used to reduce the current or the sensor will not work properly.

TEMPERATURE SENSOR ELECTRICAL RATINGS

Volts	Continuous Amperes	Inrush Amperes
110-120	3.00	30.0
220-240	1.50	15.0
440-480	0.75	7.5

B-4.4) Moisture Sensors:

A normally open (N/O) detector is installed in the pump seal chamber, which will detect any moisture present, and a continuity test resistor built into the motor. The test resistor is rated 1 watt at 330K ohms. The moisture sensors **MUST** be connected to an intrinsically safe moisture detector control in the control panel which includes a continuity test circuit, see Figure 4 for typical wiring diagram. The normally closed (N/C) contact of the moisture detector **MUST** be connected in series with the stop button of the pilot circuit of the magnetic motor controller. Wiring must be provided from the moisture detector sensor probe leads of the motor designated W1 and W2 to terminals 9 and 10 of the 2800-XXX control. Terminal pair 1-2 must be continuously energized from an A-C supply line of electrical characteristics shown on the data table. In the event of moisture detection, the pump should be pulled and the source of the failure located and repaired. **IF MOISTURE DETECTION HAS OCCURRED, SCHEDULE MAINTENANCE AS SOON AS POSSIBLE !**

TYPICAL WIRING DIAGRAM FOR MOISTURE SENSOR RELAY

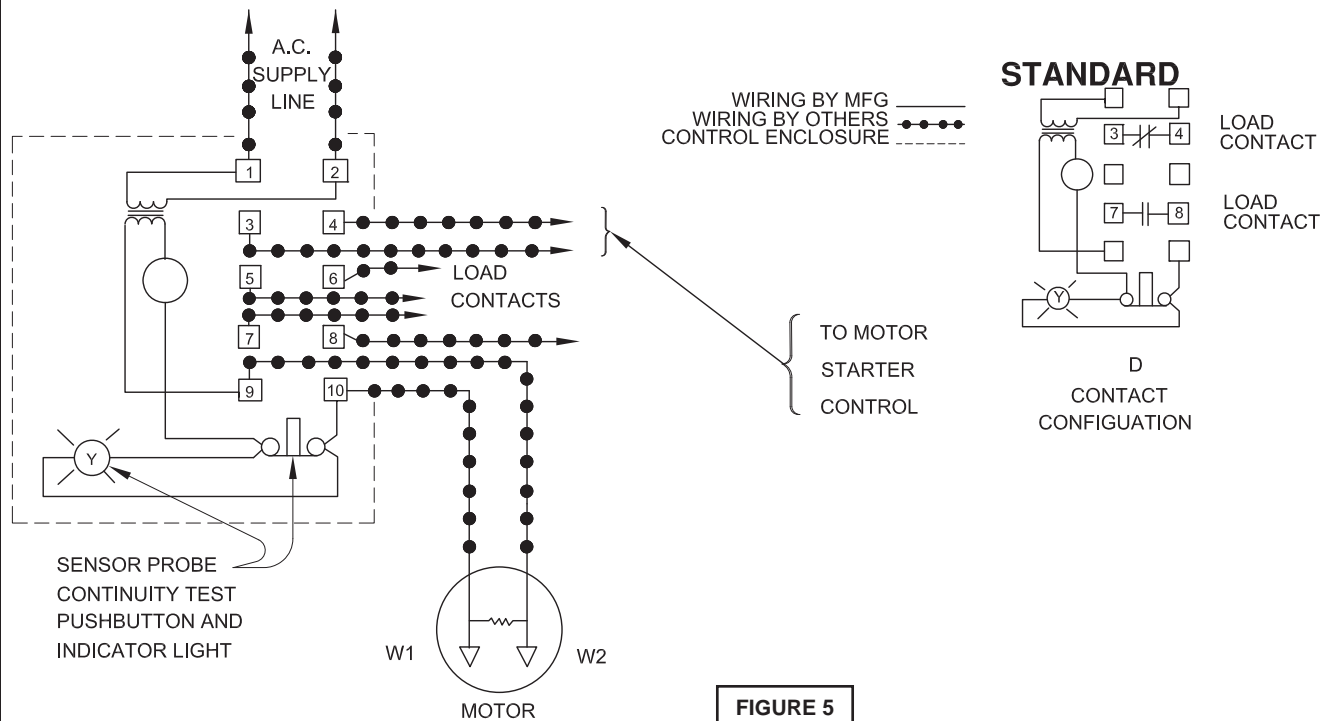

FIGURE 5

B-4.5) Control Panel and Electrical System:

The control panel and the electrical system **MUST** be properly designed and wired to include at least, but not limited to the following;

- a. Proper grounding per NEC.
- b. A temperature sensing circuit (see Fig. 4)
- c. A moisture detection circuit with continuity test circuit (see Figure 5)
- d. A level control system.
- e. A main power manual disconnect and lock out.
- f. A motor starter and overload system.
- g. An intrinsically safe level control system. It is advisable that all three phase control panels be purchased from the factory.

SECTION: C START-UP OPERATION

C-1) Check Voltage and Phase:

Before operating pump, compare the voltage and phase information stamped on the pump's identification plate to the available power.

C-2) Check Pump Rotation:

Before putting pump into service for the first time, the motor rotation must be checked. Improper motor rotation can result in poor pump performance and can damage the motor and/or pump. To check the rotation, suspend the pump freely, momentarily apply power and observe the "kickback". "Kickback" should always be in a counter-clockwise direction as viewed from the top of the pump motor housing and will always be in the opposite direction of the rotation arrows cast in the pump volute.

C-2.1) Incorrect Rotation for Three-Phase Pumps:

In the event that the rotation is incorrect for a three-phase installation, interchange any two power cable leads at the control box. Recheck the "kickback" rotation again by momentarily applying power.

C-2.2) Test Procedure For Moisture Sensor Control:

With a moisture detection control, a normally closed push button and neon indicating lamp is typically provided as a means of checking the moisture sensing components. When the push button is depressed, the indicating lamp will be illuminated to indicate (A) power is supplied to the control, (B) the control is operative, and (C) wiring to the moisture sensing probes in the motor is intact. This procedure should be performed periodically to confirm integrity of the circuit.

C-3) Start-Up Report:

Included at the end of this manual is one start-up report sheet, this sheet is to be completed as applicable. Return a copy to Barnes and store the second in the control panel or with the pump manual. It is important to record this data at initial start-up since it will be useful to refer to should servicing the pump be required in the future.

C-3.1) Identification Plate:

Record the numbers from the pump's identification plate on the START-UP REPORT provided at the end of the manual for future reference.

C-3.2) Insulation Test:

Before the pump is put into service, an insulation (megger) test should be performed on the motor. The resistance values (ohms) as well as the voltage (volts) and current (amps) should be recorded on the start-up report. Pumps/systems with an insulation value of less than 5 M-Ohms should be investigated for moisture or damaged cables before proceeding.

C-3.3) Pump-Down Test:

After the pump has been properly wired and lowered into the basin, sump or lift station, it is advisable to check the system by filling with liquid and allowing the pump to operate through it's pumping cycle. The time needed to empty the system, or pump-down time along with the volume of water, should be recorded on the start-up report.

SECTION D: PREVENTATIVE MAINTENANCE

As the motor and seal chamber are oil-filled, no lubrication or other maintenance is required, and generally Barnes Pumps will give very reliable service and can be expected to operate for years of normal sewage pumping without failing. However, as with any mechanical piece of equipment a preventive maintenance program is recommended and suggested to include the following checks:

- 1) Test moisture detector control "Test Switch" for continuity of circuit. Water in the seal chamber will energize a seal leak warning light at the control panel. This is a warning light only and does not stop the motor. It indicates the seal has leaked and must be repaired. This should be done within 2 or 3 weeks to prevent further damage. See section C-2.2.
- 2) Inspect impeller and body for excessive build-up or clogging and repair as required per section E-2.
- 3) Inspect outer shaft seal and replace as required per section E-3.
- 4) Check motor for ground leakage and proper amp draw.

SECTION E: SERVICE AND REPAIR

NOTE: All item numbers in () refer to Figures 9 & 10.



WARNING ! - Electrical power to the pump motors must be disconnected and locked out to prevent any dangerous electrical hazards or personnel danger before any service work is done to the pump.



CAUTION ! - Operating pump builds up heat and pressure; allow time for pump to cool to room temperature before handling or servicing.

E-1) Lubrication

E-1.1) Checking Oil

1. Place pump on it's side, and drain oil into a clean, dry container.
2. Check oil for contamination using an oil tester with a range to 30Kilovolts breakdown.
3. If oil is found to be clean and uncontaminated (measure above 15 KV. breakdown), refill the seal chamber as per section E-1.2.
4. If oil is found to be dirty or contaminated (or measures below 15 KV. breakdown), the pump must be carefully inspected for leaks at the shaft seal (4), before refilling with oil. To locate the leak, perform a pressure test as per section E-1.3. After leak is repaired, refill with new oil as per section E-1.2.

E-1.2) Replacing Oil:

Seal Chamber - Drain all oil from seal chamber and dispose of properly. Refill with (see parts list for amount) new cooling oil as per Table 1. An air space must remain to compensate for oil expansion (see fig. 9). Set unit on side and fill.



IMPORTANT! - Do not overfill oil. Overfilling of seal chamber with oil can create excessive and dangerous hydraulic pressure which can destroy the pump and create a hazard. Overfilling oil voids warranty.

E-1.3) Pressure Test:

Seal Chamber - Before checking the pump for leaks around the shaft seal, the oil level should be full. Remove pipe plug. Apply pipe sealant to pressure gauge assembly and tighten into pipe plug hole. Pressurize motor housing to 10 P.S.I. Use a soap solution around the sealed area and inspect joints for "air bubbles". If, after five minutes, the pressure is still holding constant, and no "bubbles" are observed, slowly bleed the pressure and remove the gauge assembly. Replace the pipe plug using a sealant. If the pressure does not hold, then the leak must be located.



CAUTION! - Pressure builds up extremely fast, increase pressure by "tapping" air nozzle. Too much pressure will damage seal. Do Not exceed 10 P.S.I. in seal chamber.

TABLE 1 - COOLING OIL - Dielectric	
SUPPLIER	GRADE
BP	Enerpar SE100
Conoco	Pale Paraffin 22
Mobil	D.T.E. Oil Light
G & G Oil	Circulating 22
Imperial Oil	Voltesso-35
Shell Canada	Transformer-10
Texaco	Diala-Oil-AX
Woco	Premium 100

E-2) Impeller and Volute Service:

E-2.1) Disassembly and Inspection:

To clean out the volute (11), or clean out or replace impeller (6), disconnect power, remove cap screws (2) then vertically lift motor assembly from the pump body (11). Clean out the volute, if necessary, clean and examine impeller (6) for pitting or wear, replace if required. To remove Impeller (6), remove cap screw (8) and washer (8A). The impeller is keyed onto the shaft with a square key (7) and to remove, pull impeller straight off the shaft using a wheel puller if required. Inspect o-ring (9) and replace if cut or damaged. Before reinstallation, check the motor shaft and impeller bore for damage.

WARNING! These motors are listed for application in Class 1, Division 1, Groups C & D, EXPLOSION PROOF environments. All repairs, other than lead reconnects and outer seal replacement, shall be performed by an authorized Crane Pumps & Systems Service Facility. Any other repairs performed by the customer or Non-Authorized Crane Pumps & Systems Service facilities negates the listing and motor warranty.



E-2.2) Reassembly:

To install impeller (6), apply a thin film of oil to motor shaft and slide impeller straight onto shaft, keeping keyways lined up. Drive key (7) into keyway. Thread cap screw (8) and washer (8A) into shaft and torque to 45 ft. lbs. Rotate impeller to check for binding. Place o-ring (9) on seal plate pilot diameter lining up holes and install impeller and motor assembly onto volute (11). Loctite cap screws (2), insert into volute and motor assembly and torque to 35 ft. lbs. Check for free rotation of motor and impeller.

E-3) Outer Shaft Seal Service:



CAUTION! - Handle seal parts with extreme care. DO NOT scratch or mar lapped surfaces.

E-3.1) Disassembly and Inspection:

To expose outer shaft seal (4) for examination, remove Impeller and Volute per Section F-1.1. Set motor assembly (1) in the inverted position to prevent loss of oil. Remove snap ring from motor shaft, then retaining ring (5), spring (4C) and rotating member (4B) from shaft. See Figure 5 Examine all seal parts and especially contact faces. Inspect seal for signs of wear such as uneven wear pattern on stationary members, chips and scratches on either seal face. **DO NOT** interchange seal components, replace the entire shaft seal (4). If replacing seal, remove stationary (4A) from mounting plate by prying out with flat screw driver.

E-3.2) Reassembly:

Lightly oil (**DO NOT use grease**) outer surface of stationary member (4A). Press stationary member (4A) firmly into mounting plate using a seal pusher aligning seal with pin, nothing but the seal pusher is to come in contact with seal face (see Figure 7).

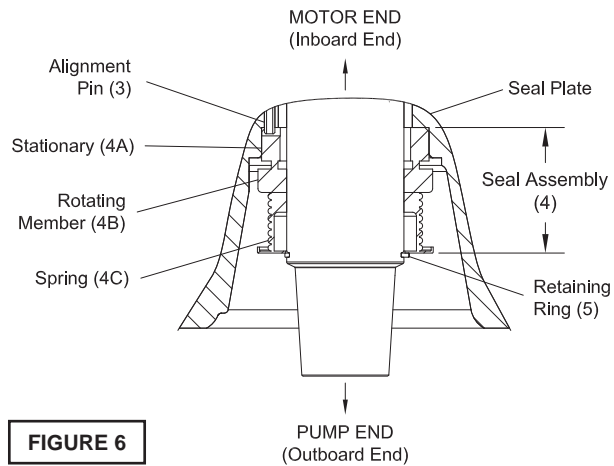

FIGURE 6

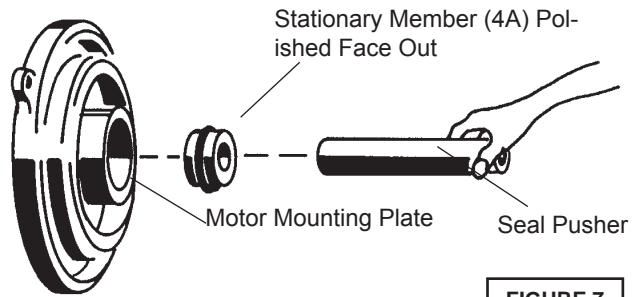

FIGURE 7

Make sure the stationary member is in straight and that the rubber ring is not out of its groove. Lightly oil (**DO NOT use grease**) shaft and inner surface of bellows on rotating member (4B) see Figure 8. With lapped surface of rotating member (4B) facing inward toward stationary member (4A), slide rotating member (4B) onto shaft using a seal pusher, until lapped faces of (4A) and (4B) are together. (see Figure 8).

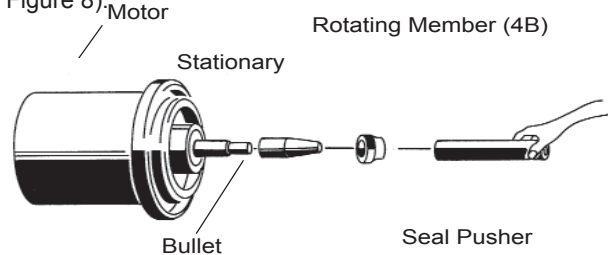

FIGURE 8



IMPORTANT! - It is extremely important to keep seal faces clean during assembly. dirt particles lodged between these faces will cause the seal to leak.

Place spring (4C) over shaft and in place on rotating member (4B), making sure it is seated on retainer and not cocked or resting on bellows tail. Slide retaining ring (5) over shaft and let rest on spring (4C). Replace snap ring onto motor shaft. Inspect gasket (9) and replace if cut or damaged. Assemble impeller and volute as outlined in paragraph E-1.2.

SECTION: F REPLACEMENT PARTS

F-1 ORDERING REPLACEMENT PARTS:

When ordering replacement parts, ALWAYS furnish the following information:

1. Pump serial number and date code. (Paragraph F-4)
2. Pump model number. (Paragraph F-3)
3. Pump part number. (Paragraph F-2)
4. Part description.
5. Item part number.
6. Quantity required.
7. Shipping instructions.
8. Billing Instructions.

CRANE		PUMPS & SYSTEMS Piqua, Ohio		BARNES™	
Power	Ph.	RPM	Volts		
Hz.	FLA.	SFA	SF		
Ambient 40°C	Duty CONT.	Code	Weight	Part No.	
Model No.	Serial No.		Imp. Dia.		

- CONNECT THERMAL CONTACTS
- SUBMERSIBLE TO 66 FEET
- SUBMERSIBLE SEWAGE PUMP

WARNING

1. TO REDUCE RISK OF ELECTRICAL SHOCK: A.) SEE INSTRUCTION MANUAL FOR PROPER INSTALLATION. B.) PUMP MUST BE PROPERLY GROUNDED IN ACCORDANCE WITH THE NATIONAL ELECTRICAL CODE AND ALL LOCAL CODES. C.) DISCONNECT THE PUMP FROM THE POWER SOURCE BEFORE HANDLING OR SERVICING. D.) INSTALLATION AND SERVICE SHALL BE CONDUCTED BY A QUALIFIED PERSON.
2. USE WITH APPROVED MOTOR CONTROL THAT MATCHES MOTOR INPUT IN FULL LOAD AMPERES WITH OVERLOAD ELEMENT(S) SELECTED OR ADJUSTED IN ACCORDANCE WITH CONTROL INSTRUCTIONS. (UTILISER UN DÉMARREUR APPROUVÉ CONVENANT AU COURANT À PLEINECHARGE DU MOTEUR ET DONT LES ÉLÉMENTS THERMIQUES SONT RÉGLÉS OU CHOISIS CONFORMÉMENT AUX INSTRUCTION QUI L'ACCOMPAGNENT).
3. KEEP CLEAR OF SUCTION AND DISCHARGE OPENING AT ALL TIMES WHERE POWER IS CONNECTED.
4. MOTOR HOUSING WILL CONTAIN HOT OIL UNDER PRESSURE, ALLOW MOTOR TO COOL BEFORE OPENING.
5. THIS PUMP IS NOT INTENDED FOR USE IN SWIMMING POOLS, DECORATIVE FOUNTAINS OR INSTALLATIONS IN WHICH HUMAN CONTACT WITH THE PUMPED MEDIA IS A COMMON OCCURENCE.
6. DO NOT PUMP FLAMMABLE LIQUIDS.
7. DO NOT REMOVE CORD AND STRAIN RELIEF.
8. DO NOT CONNECT CONDUIT TO PUMP.

127264

CE

CSA 108
UL 778
US LR18567

F-2 PART NUMBER:

This number is used for ordering and obtaining information.

F-3 MODEL NUMBER:

This designation consists of numbers and letters which represent the discharge size, series, horsepower, motor phase and voltage, speed and pump design. This number is used for ordering and obtaining information.

F-4 SERIAL NUMBER:

The serial number block will consist of a six digit number, which is specific to each pump and may be preceded by an alpha character, which indicates the plant location. This number will also be suffixed with a four digit number, which indicates the date the unit was built (Date Code).

EXAMPLE: A012345 0490.

Reference the six digit portion (Serial Number) of this number when referring to the product.

TROUBLESHOOTING

CAUTION ! Always disconnect the pump from the electrical power source before handling.
 If the system fails to operate properly, carefully read instructions and perform maintenance recommendations.
 If operating problems persist, the following chart may be of assistance in identifying and correcting them:
 MATCH "CAUSE" NUMBER WITH CORRELATING "CORRECTION" NUMBER.

NOTE: Not all problems and corrections will apply to each pump model.

PROBLEM	CAUSE	CORRECTION
Pump will not run	<ol style="list-style-type: none"> 1. Poor electrical connection, blown fuse, tripped breaker or other interruption of power, improper power supply. 2. Motor or switch inoperative (to isolate cause, go to manual operation of pump). 2a. Float movement restricted. 2b. Switch will not activate pump or is defective. 2c. Defective motor 3. Insufficient liquid level. 	<ol style="list-style-type: none"> 1. Check all electrical connections for security. Have electrician measure current in motor leads, if current is within $\pm 20\%$ of locked rotor Amps, impeller is probably locked. If current is 0, overload may be tripped. Remove power, allow pump to cool, then recheck current. 2a. Reposition pump or clean basin as required to provide adequate clearance for float. 2b. Disconnect level control. Set ohmmeter for a low range, such as 100 ohms full scale and connect to level control leads. Actuate level control manually and check to see that ohmmeter shows zero ohms for closed switch and full scale for open switch. (Float Switch). 2c. Check winding insulation (Megger Test) and winding resistance. If check is outside of range, dry and recheck. If still defective, replace per service instructions.
Pump will not turn off	<ol style="list-style-type: none"> 2a. Float movement restricted. 2b. Switch will not activate pump or is defective. 4. Excessive inflow or pump not properly sized for application. 9. Pump may be airlocked 14. H-O-A switch on panel is in "HAND" position 	<ol style="list-style-type: none"> 2b. Disconnect level control. Set ohmmeter for a low range, such as 100 ohms full scale and connect to level control leads. Actuate level control manually and check to see that ohmmeter shows zero ohms for closed switch and full scale for open switch. (Float Switch). 2c. Check winding insulation (Megger Test) and winding resistance. If check is outside of range, dry and recheck. If still defective, replace per service instructions.
Pump hums but does not run	<ol style="list-style-type: none"> 1. Incorrect voltage 8. Impeller jammed or loose on shaft, worn or damaged, impeller cavity or inlet plugged. 	<ol style="list-style-type: none"> 2c. Check winding insulation (Megger Test) and winding resistance. If check is outside of range, dry and recheck. If still defective, replace per service instructions.
Pump delivers insufficient capacity	<ol style="list-style-type: none"> 1. Incorrect voltage. 4. Excessive inflow or pump not properly sized for application. 5. Discharge restricted. 6. Check valve stuck closed or installed backwards. 7. Shut-off valve closed. 8. Impeller jammed or loose on shaft, worn or damaged, impeller cavity or inlet plugged. 9. Pump may be airlocked. 10. Pump running backwards 	<ol style="list-style-type: none"> 3. Make sure liquid level is at least equal to suggested turn-on point. 4. Recheck all sizing calculations to determine proper pump size. 5. Check discharge line for restrictions, including ice if line passes through or into cold areas. 6. Remove and examine check valve for proper installation and freedom of operation. 7. Open valve.
Pump cycles too frequently or runs periodically when fixtures are not in use	<ol style="list-style-type: none"> 6. Check valve stuck closed or installed backwards. 11. Fixtures are leaking. 15. Ground water entering basin. 	<ol style="list-style-type: none"> 8. Check impeller for freedom of operation, security and condition. Clean impeller and inlet of any obstruction. 9. Loosen union slightly to allow trapped air to escape. Verify that turn-off level of switch is set so that the suction is always flooded. Clean vent hole.
Pump shuts off and turns on independent of switch, (trips thermal overload protector). CAUTION! Pump may start unexpectedly. Disconnect power supply.	<ol style="list-style-type: none"> 1. Incorrect voltage. 4. Excessive inflow or pump not properly sized for application. 8. Impeller jammed, loose on shaft, worn or damaged, impeller cavity or inlet plugged. 12. Excessive water temperature. (internal protection only) 	<ol style="list-style-type: none"> 10. Check rotation. If power supply is three phase, reverse any two of three power supply leads to ensure proper impeller rotation.. 11. Repair fixtures as required to eliminate leakage.
Pump operates noisily or vibrates excessively	<ol style="list-style-type: none"> 2c. Worn bearings, motor shaft bent. 5. Debris in impeller cavity or broken impeller 10. Pump running backwards 13. Piping attachments to building structure too rigid or too loose. 	<ol style="list-style-type: none"> 12. Check pump temperature limits & fluid temperature. 13. Replace portion of discharge pipe with flexible connector. 14. Turn to automatic position. 15. Check for leaks around basin inlet and outlets.

Cross Section

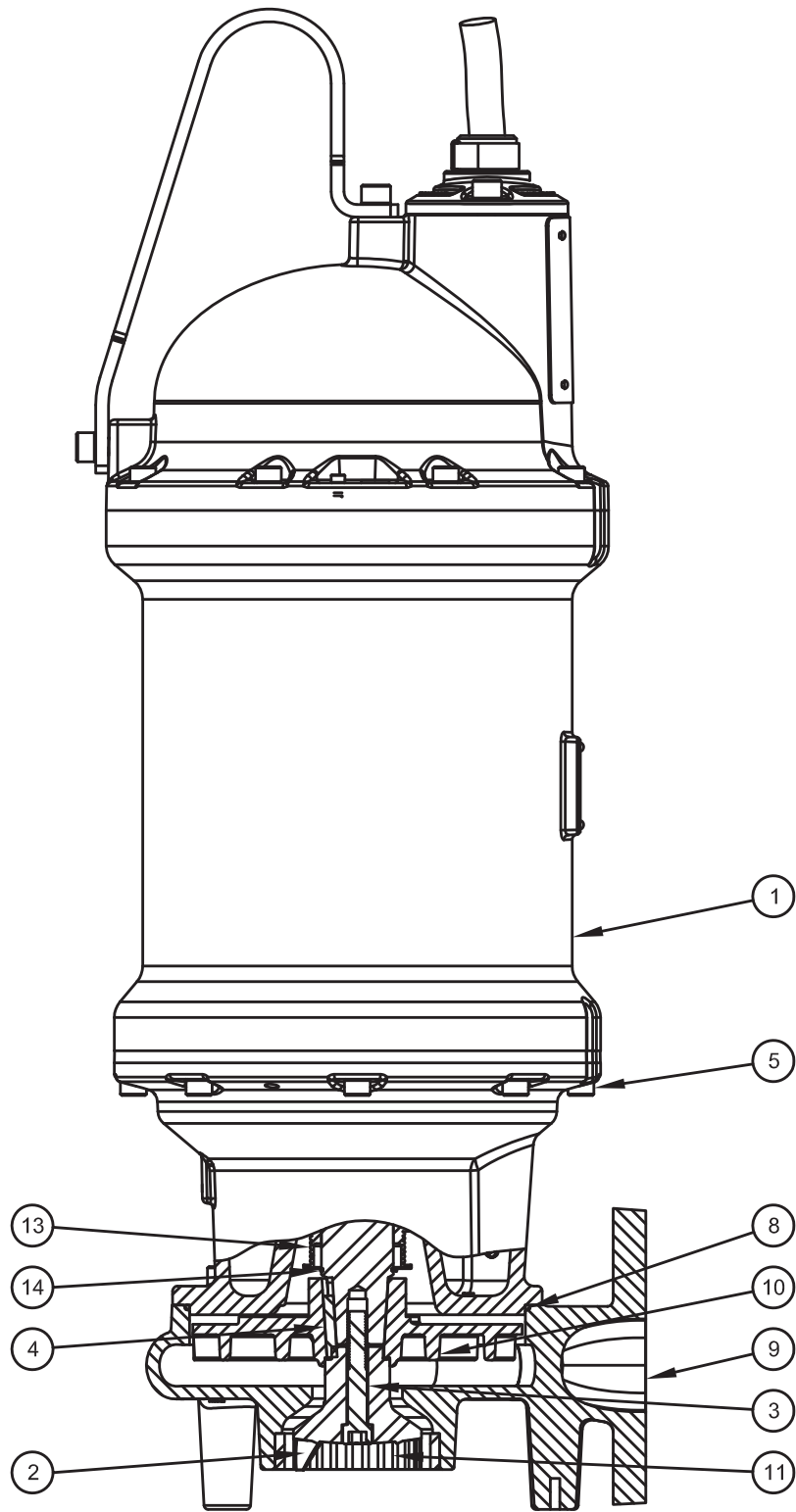

FIGURE 9

Exploded View

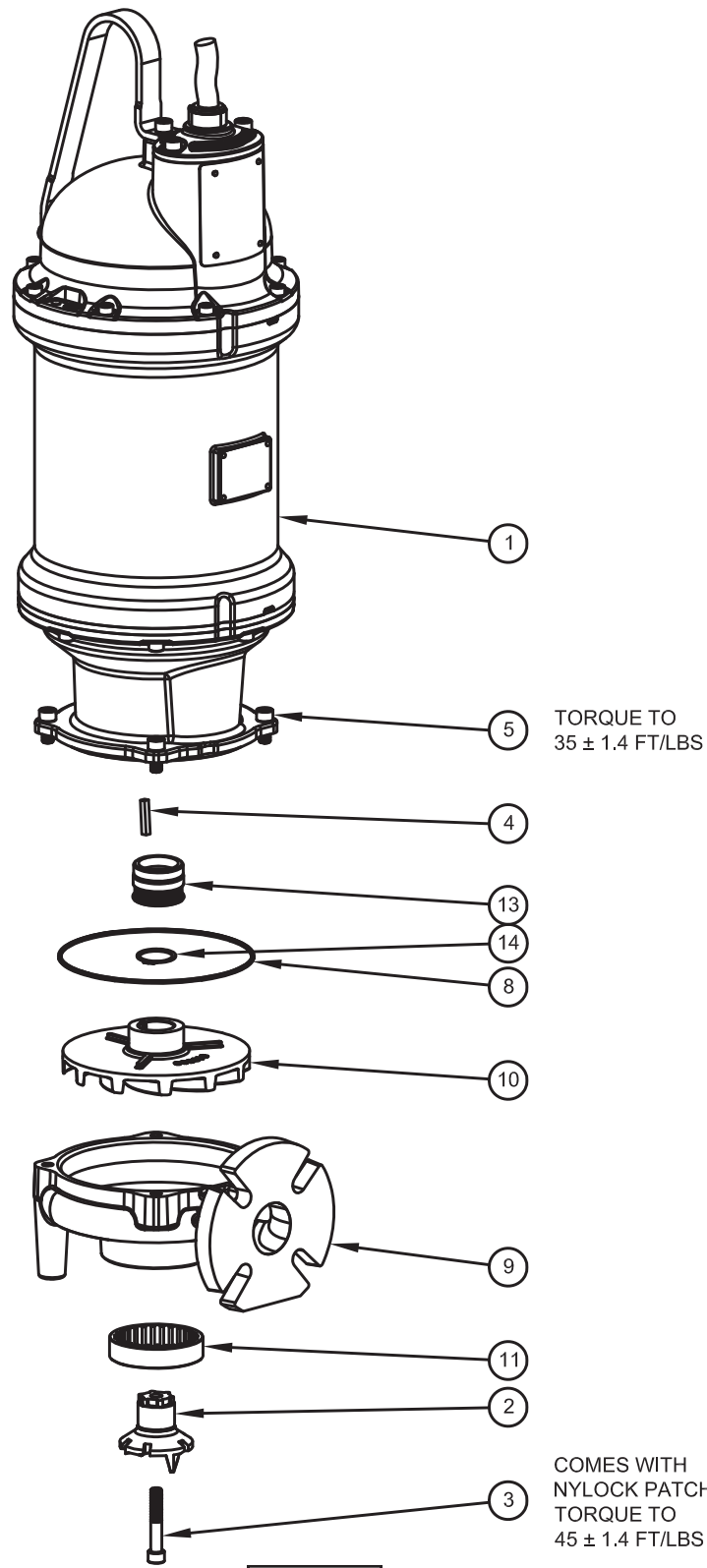

FIGURE 10

PARTS LIST

Outboard Seal KitSee Chart
Hardware Kit141535
Impeller Attachment Kit141534
Cord Attachment Kit..... 140152-21
Leg Kit125506

ITEM	QTY	PART NO.	DESCRIPTION	MATERIAL
1	1	No Resale	Driver Assembly	
2	1	141057	Cutter, Radial, 3.10" Dia., Drive	440 Stainless Steel
3	1	136284-70	Screw, SHCS, M12 x 1.75 x 70	Stainless Steel
4	1	Q21-20-J8	Key, .25 x .25 x 1.50"	303 Stainless Steel
5	4	127223	Screw, SHCS, M12 x 1.75 x 25	300 Stainless Steel
8	1	125857-200	O-Ring, M3 x 200, 70 Duro	Buna-N
9	1	141060	Volute, Grinder, Flange	Class 30 Cast Iron
10	1	See Chart	Impeller, Vortex	Class 30 Cast Iron
11	1	141062	Ring, Shredding, 4.00" O.D., HF	440 Stainless Steel
13	1	See Chart	Seal, Mechanical	See Chart
14	1	129381	Retaining Ring	Stainless Steel

Outboard Seal Kits	
Seal Kit Part No.	O.B Seal Material
141537	Carbon / Ceramic
141537SD	Silicon Carbide / Silicon Carbide
141537SB	Tungsten Carbide / Tungsten Carbide

Seal Kit includes:
<ul style="list-style-type: none"> • Volute O-Ring • Seal • Impeller Screw • External Retaining Ring

NOTE: Kit contains hardware your pump may not require.

Cord Attachment Kit includes:
<ul style="list-style-type: none"> • Attachment screws

Impeller Attachment Kit includes:
<ul style="list-style-type: none"> • Impeller Bolt

Hardware Kit includes:
<ul style="list-style-type: none"> • Impeller key • Volute attachment screws • Impeller attachment screw

NOTE: Kits contain hardware your pump may not require.

Impeller Chart	
Part No.	Trim Dia. mm (in)
141061	203mm (8.00in)
141061TA	200mm (7.88in)
141061TB	197mm (7.75in)
141061TC	194mm (7.63in)
141061TD	191mm (7.50in)
141061TE	187mm (7.38in)
141061TF	184mm (7.25in)
141061TG	181mm (7.13in)
141061TH	178mm (7.00in)
141061TJ	175mm (6.88in)
141061TK	171mm (6.75in)
141061TL	168mm (6.63in)
141061TM	165mm (6.50in)
141061TN	162mm (6.38in)
141061TP	159mm (6.25in)
141061TQ	156mm (6.13in)
141061TR	152mm (6.00in)
141061TS	146mm (5.75in)

Power Cable Chart

Part No.	Length (feet)	Volt	Max. Amps	Cord Size	Cord O.D. +/- .02in (.5mm)
125497XC	30	400-600	31.7	12/4 - 18/4	0.86in (22.0mm)
125497XF	50	400-600	31.7	12/4 - 18/4	0.86in (22.0mm)
125497XJ	75	400-600	31.7	12/4 - 18/4	0.86in (22.0mm)
125498XL	100	400-600	31.7	12/4 - 18/4	0.86in (22.0mm)
125498XC	30	208-240	59.0	8/4 - 18/4	1.12in (28.4mm)
125498XF	50	208-240	59.0	8/4 - 18/4	1.12in (28.4mm)
125499XJ	75	208-240	59.0	8/4 - 18/4	1.12in (28.4mm)
125499XL	100	208-240	59.0	8/4 - 18/4	1.12in (28.4mm)
125499XC	30	400-600	59.0	8/4 - 18/4	1.12in (28.4mm)
125499XF	50	400-600	59.0	8/4 - 18/4	1.12in (28.4mm)
125499XJ	75	400-600	59.0	8/4 - 18/4	1.12in (28.4mm)
125499XL	100	400-600	59.0	8/4 - 18/4	1.12in (28.4mm)

BARNES®



burks®

WEINMAN®

DEMING®

PROSSER®

Limited 24 Month Warranty

Crane Pumps & Systems warrants that products of our manufacture will be free of defects in material and workmanship under normal use and service for twenty-four (24) months after manufacture date, when installed and maintained in accordance with our instructions. This warranty gives you specific legal rights, and there may also be other rights which vary from state to state. In the event the product is covered by the Federal Consumer Product Warranties Law (1) the duration of any implied warranties associated with the product by virtue of said law is limited to the same duration as stated herein, (2) this warranty is a LIMITED WARRANTY, and (3) no claims of any nature whatsoever shall be made against us, until the ultimate consumer, his successor, or assigns, notifies us in writing of the defect, and delivers the product and/or defective part(s) freight prepaid to our factory or nearest authorized service station. Some states do not allow limitations on how long an implied warranty lasts, so the above limitation may not apply. **THE SOLE AND EXCLUSIVE REMEDY FOR BREACH OF ANY AND ALL WARRANTIES WITH RESPECT TO ANY PRODUCT SHALL BE TO REPLACE OR REPAIR AT OUR ELECTION, F.O.B. POINT OF MANUFACTURE OR AUTHORIZED REPAIR STATION, SUCH PRODUCTS AND/OR PARTS AS PROVEN DEFECTIVE. THERE SHALL BE NO FURTHER LIABILITY, WHETHER BASED ON WARRANTY, NEGLIGENCE OR OTHERWISE.** Unless expressly stated otherwise, guarantees in the nature of performance specifications furnished in addition to the foregoing material and workmanship warranties on a product manufactured by us, if any, are subject to laboratory tests corrected for field performance. Any additional guarantees, in the nature of performance specifications must be in writing and such writing must be signed by our authorized representative. Due to inaccuracies in field testing if a conflict arises between the results of field testing conducted by or for user, and laboratory tests corrected for field performance, the latter shall control. **RECOMMENDATIONS FOR SPECIAL APPLICATIONS OR THOSE RESULTING FROM SYSTEMS ANALYSES AND EVALUATIONS WE CONDUCT WILL BE BASED ON OUR BEST AVAILABLE EXPERIENCE AND PUBLISHED INDUSTRY INFORMATION. SUCH RECOMMENDATIONS DO NOT CONSTITUTE A WARRANTY OF SATISFACTORY PERFORMANCE AND NO SUCH WARRANTY IS GIVEN.**

This warranty shall not apply when damage is caused by (a) improper installation, (b) improper voltage (c) lightning (d) excessive sand or other abrasive material (e) scale or corrosion build-up due to excessive chemical content. Any modification of the original equipment will also void the warranty. We will not be responsible for loss, damage or labor cost due to interruption of service caused by defective parts. Neither will we accept charges incurred by others without our prior written approval.

This warranty is void if our inspection reveals the product was used in a manner inconsistent with normal industry practice and/or our specific recommendations. The purchaser is responsible for communication of all necessary information regarding the application and use of the product. **UNDER NO CIRCUMSTANCES WILL WE BE RESPONSIBLE FOR ANY OTHER DIRECT OR CONSEQUENTIAL DAMAGES, INCLUDING BUT NOT LIMITED TO TRAVEL EXPENSES, RENTED EQUIPMENT, OUTSIDE CONTRACTOR FEES, UNAUTHORIZED REPAIR SHOP EXPENSES, LOST PROFITS, LOST INCOME, LABOR CHARGES, DELAYS IN PRODUCTION, IDLE PRODUCTION, WHICH DAMAGES ARE CAUSED BY ANY DEFECTS IN MATERIAL AND/OR WORKMANSHIP AND/OR DAMAGE OR DELAYS IN SHIPMENT. THIS WARRANTY IS EXPRESSLY IN LIEU OF ANY OTHER EXPRESS OR IMPLIED WARRANTY, INCLUDING ANY WARRANTY OF MERCHANTABILITY OR FITNESS FOR A PARTICULAR PURPOSE.**

No rights extended under this warranty shall be assigned to any other person, whether by operation of law or otherwise, without our prior written approval.

CRANE®

PUMPS & SYSTEMS

A Crane Co. Company

420 Third Street
Piqua, Ohio 45356
(937) 778-8947
Fax (937) 773-7157
www.cranepumps.com

83 West Drive
Brampton, Ont. Canada L6T 2J6
(905) 457-6223
Fax (905) 457-2650

**IMPORTANT!
WARRANTY REGISTRATION**

Your product is covered by the enclosed Warranty.
To complete the Warranty Registration Form go to:

<http://www.cranepumps.com/ProductRegistration/>

If you have a claim under the provision of the warranty, contact your local
Crane Pumps & Systems, Inc. Distributor.

**RETURNED GOODS
RETURN OF MERCHANDISE REQUIRES A "RETURNED GOODS AUTHORIZATION".
CONTACT YOUR LOCAL CRANE PUMPS & SYSTEMS, INC. DISTRIBUTOR.**



**Products Returned Must Be Cleaned, Sanitized,
Or Decontaminated As Necessary Prior To Shipment,
To Insure That Employees Will Not Be Exposed To Health
Hazards In Handling Said Material. All Applicable Laws
And Regulations Shall Apply.**



A Crane Co. Company

PUMPS & SYSTEMS

START-UP REPORT

General Information

Pump Owner's Name: _____
 Address: _____
 Location of Installation: _____
 Contact Person: _____ Phone: _____
 Purchased From: _____

Nameplate Data

Pump Model #: _____ Serial #: _____
 Part #: _____ Impeller Diameter: _____
 Voltage: _____ Phase: _____ Ø Hertz: _____ Horsepower: _____
 Full Load Amps: _____ Service Factor Amps: _____
 Motor Manufacturer: _____

Controls

Control panel manufacturer: _____
 Model/Part number: _____
 Number of pumps operated by control panel: _____
 Short circuit protection? YES___ NO___ Type: _____
 Number and size of short circuit device(s): _____ Amp rating: _____
 Overload Type: _____ Size: _____ Amp rating: _____
 Do protection devices comply with pump and motor Amp rating? YES___ NO___
 Are all electrical and panel entry connections tight? YES___ NO___
 Is the interior of the panel dry? YES___ NO___
 Liquid level Control Brand and Model: _____

Pre-Startup

All Pumps

Type of equipment: NEW___ REBUILT___ USED___
 Condition of equipment at Start-Up: DRY___ WET___ MUDDY___
 Was Equipment Stored? YES___ NO___ Length of Storage: _____
 Liquid being pumped: _____ Liquid Temperature: _____
 Supply Voltage/Phase/Frequency matches nameplate? YES___ NO___
 Shaft turns freely? YES___ NO___
 Direction of rotation verified for 3Ø motors? YES___ NO___
 Debris in piping or wet well? YES___ NO___
 Debris removed in your presence? YES___ NO___
 Pump case/wet well filled with liquid before startup? YES___ NO___
 Is piping properly supported? YES___ NO___

Non-Submersible Pumps

Is base plate properly installed / grouted? YES___ NO___ N/A___
 Coupling Alignment Verified per I&O Manual? YES___ NO___ N/A___
 Grease Cup/Oil Reservoir Level checked? YES___ NO___ N/A___

Submersible Pumps

Resistance of cable and pump motor (measured at pump control):

Red-Black: _____ Ohms(Ω) Red-White: _____ Ohms(Ω) White-Black: _____ Ohms(Ω)

Resistance of Ground Circuit between Control Panel and outside of pump: _____ Ohms(Ω)

MEG Ohms check of insulation:

Red to Ground: _____ White to Ground: _____ Black to Ground: _____

Operational Checks

Is there noise or vibration present? YES___ NO___ Source of noise/vibration: _____

Does check valve operate properly? YES___ NO___ N/A___

Is system free of leaks? YES___ NO___ Leaks at: _____

Does system appear to operate at design flow rate? YES___ NO___

Nominal Voltage: _____ Phase: 1Ø 3Ø (select one)

Voltage Reading at panel connection, Pump OFF: L1, L2 _____ L2, L3 _____ L1, L3 _____

Voltage Reading at panel connection, Pump ON: L1, L2 _____ L2, L3 _____ L1, L3 _____

Amperage Draw, Pump ON: L1 _____ L2 _____ L3 _____

Submersible Pumps

Are BAF and guide rails level / plumb? YES___ NO___

Is pump seated on discharge properly? YES___ NO___

Are level controls installed away from turbulence? YES___ NO___

Is level control operating properly? YES___ NO___

Is pump fully submerged during operation? YES___ NO___

Follow up/Corrective Action Required

YES___ NO___

Additional Comments:

Startup performed by: _____ Date: _____

Present at Start-Up

() Engineer: _____ () Operator: _____

() Contactor: _____ () Other: _____

All parties should retain a copy of this report for future trouble shooting/reference



PUMPS & SYSTEMS

A Crane Co. Company

420 Third Street
Piqua, Ohio 45356
(937) 778-8947
Fax (937) 773-7157
www.cranepumps.com

83 West Drive
Brampton, Ont. Canada L6T 2J6
(905) 457-6223
Fax (905) 457-2650