

4" BREAK AWAY FITTING

NEW 4x4 Break Away Fitting replaces the 4x4 BAFs previously available, BAF-4 and BAF-E4. The BAF 4x6 is a new addition to our offering.

Features

- Slide Rail Adapters with non-metallic anti-spark sleeves are used with **BOTH** standard and X-Pruf pumps, eliminating costly bronze slide fittings.
- The rail size is 2" pipe for greater rigidity.
- The discharge flange is slotted to accommodate **BOTH** ANSI and ISO piping.
- The elevation of the pump discharge has been raised slightly to accommodate long-footed pumps on flat basin floors.
- Clamp-style Slide Rail Adapter provides sealing to 275ft (120 PSIG) of pump discharge head.
- Large u-shaped gasket on Slide Rail Adapter seals fitting to BAF with no metal-to-metal contact.
- BAF and Slide Rail Adapter provided with two coats (10-12 mil DFT) of DuPont Corlar® epoxy paint. Corlar is optimized for long lasting coating systems in submerged services.
- Base elbow footprint has been increased by 38% for greater stability.

Break Away Fittings, consisting of a base elbow and slide rail adapter plus brackets and hardware, provide for easy installation and removal of Barnes 4SH and 4SE sewage pumps in permanent wet well installations.



Shown with 4SH

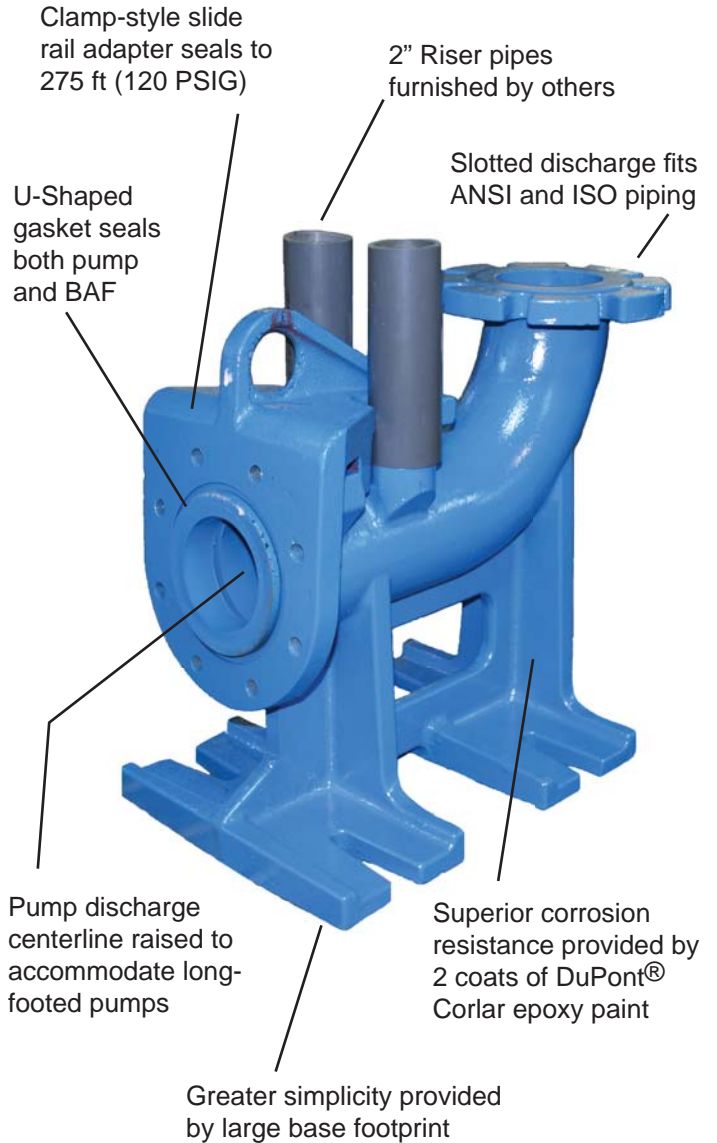
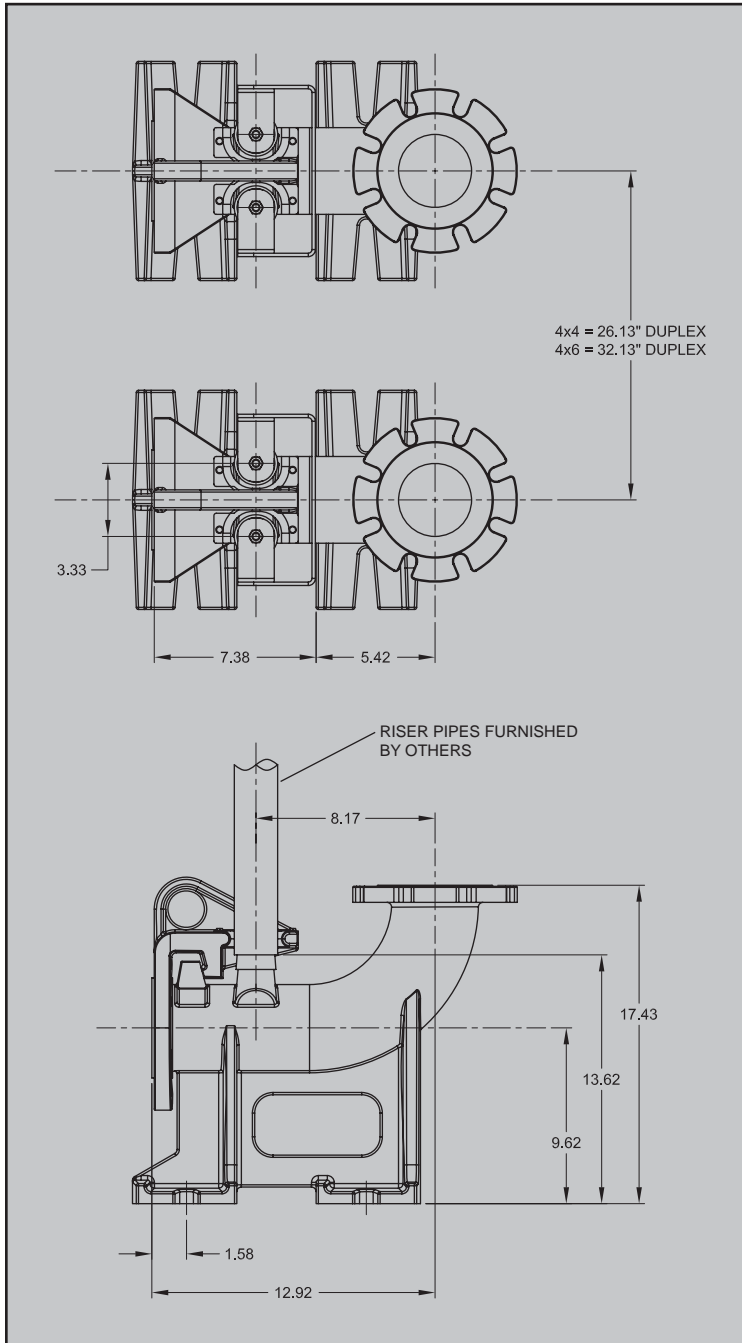

For more information, contact your Crane Pumps & System Barnes distributor or go to www.cranepumps.com



A Crane Co. Company

PUMPS & SYSTEMS

Crane Pumps & Systems
420 Third Street
Piqua, Ohio 45356
(937) 778-8947
Fax (937) 773-7157
www.cranepumps.com

Crane Pumps & Systems Canada
83 West Drive
Brampton, Ont. Canada L6T 2J6
(905) 457-6223
Fax (905) 457-2650