

CRANE

PUMPS & SYSTEMS

2
2010

Pumps & SYSTEMS

IN BRIEF:

SITE / LOCATION:

Fairfield Glade, TN
Hilly, lakefront community with over 1,000
sewer connections
www.fairfieldglade.net

PROBLEM:

E/One sewer systems were not achieving
expected service life and were in continu-
ous need of repair. Dissatisfied with
manufacturer's support and product
reliability Fairfield Glade's Community
Services Director, Jeff Warren, looked for
help.

SOLUTION:

The patented Omni Grind Plus™ (OGP)
grinder pump provides maximum flexibil-
ity and "universal" residential hydraulic
coverage. The OGP pump is available with
the replacement core unit and the Barnes
EcoTRAN system. There are several
advantages of the system's design:

- NSF certified patented Slicerator (only
pressure sewer pump with this
certification!)
- Patented ESPS level switch - improves
service life and reduces service calls
- Improved reliability and easy
installation

Applications & Solutions

Reliability & Service Capture Competitor's Reference Site

The Barnes® EcoTRAN® System Solution

Community Services Director, Jeff Warren, of Fairfield Glade Community Club was frustrated with the service, product life and total cost of ownership of E/One products. Crane Pumps & Systems, in partnership with our distributor Southern Sales, developed a solution to Mr. Warren's challenges. Southern Sales offered the community a trial Barnes Omni Grind Plus™ (OGP) replacement core to address their failing E/One units. After installation and 3 months of dependable operation, Mr. Warren recommended to the community board that Fairfield Glade switch from E/One products to Crane Pumps & Systems' Barnes Pressure Sewer systems, including the OGP pump for the replacement pump cores and the Barnes EcoTRAN for new applications.

Fairfield Glade has reduced operating
expenses while increasing the service
life of their system. Today, Mr. Warren
is a proud and welcome reference for
CP&S Pressure Sewer solutions.



Replacement Core

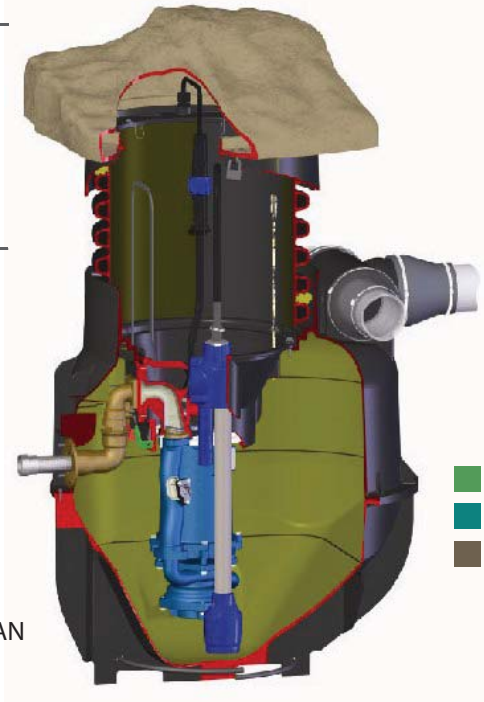

Barnes EcoTRAN