

# SOLIDS *Handling*

**SHV** Submersible Solids Handling Pumps utilize vortex impellers for outstanding clogging resistance from stringy solids. The combination of Inverter Duty Rated motors and steep performance curves make them ideal for variable speed operation, and the external coating system provides corrosion resistance designed specifically for wet well applications. Motors range from 7.5 to 30 HP at 3450 RPM.

## Designed for Solids Handling with Less Clogging

The SHV uses a recessed vortex impeller:

- Full 3" spherical solids handling capability
- Easily handles stringy solids
- Pump-out vanes protect the mechanical seal area

## Designed for Variable Frequency Drive

The SHV is optimized for variable speed drive:

- Steep curves provide straight-forward flow control
- Inverter Duty Rated Premium Efficient motors per NEMA MG1 Part 31 for dependable VFD operation

## Designed for Longer Mechanical Seal Life

The SHV provides features to extend seal life:

- Grit-resistant silicon carbide or tungsten carbide pump-end seal faces
- Heavy Shaft design to minimize deflection
- Standard, non-proprietary seals - readily available



## Designed for Longer Bearing Life

The SHV bearing system is optimized for bearing life:

- Heavy-Duty shaft reduces deflection loads
- Oil lubrication provides superior life compared to grease
- Bearing ratings of 50,000 hours at minimum flow (2.0 fps)

## Designed for Tough Wet Well Environments

The SHV uses components and coating systems to provide outstanding corrosion resistance:

- Two coats of DuPont Corlar® modified polyamide epoxy provides outstanding external corrosion protection
- The pump shaft, all fasteners and the large lifting bail are corrosion-resistant stainless steel for long life



# BARNES®

208-230/460-575 V Selection Via Cord & Plug (Up to 20 HP) No integral wiring changes required

1.2 service factor Inverter Duty Rated. Class F system with Class H magnet wire.

Pressed stator provides greater rigidity for better seal life and optimal heat transfer

Smooth castings for easy wash down

Large shaft diameter reduces deflection for longer seal life

High capacity bearings to optimize life; 50,000 Hour life at 2 fps flow

Moisture Detection Probe alerts pending seal problems before water can enter motor

Slotted discharge for 4" ANSI or 100gpm ISO flanges

Optional moveable adapters to match Barnes and competitor base elbows (not shown) both 4 inch and 100mm metric

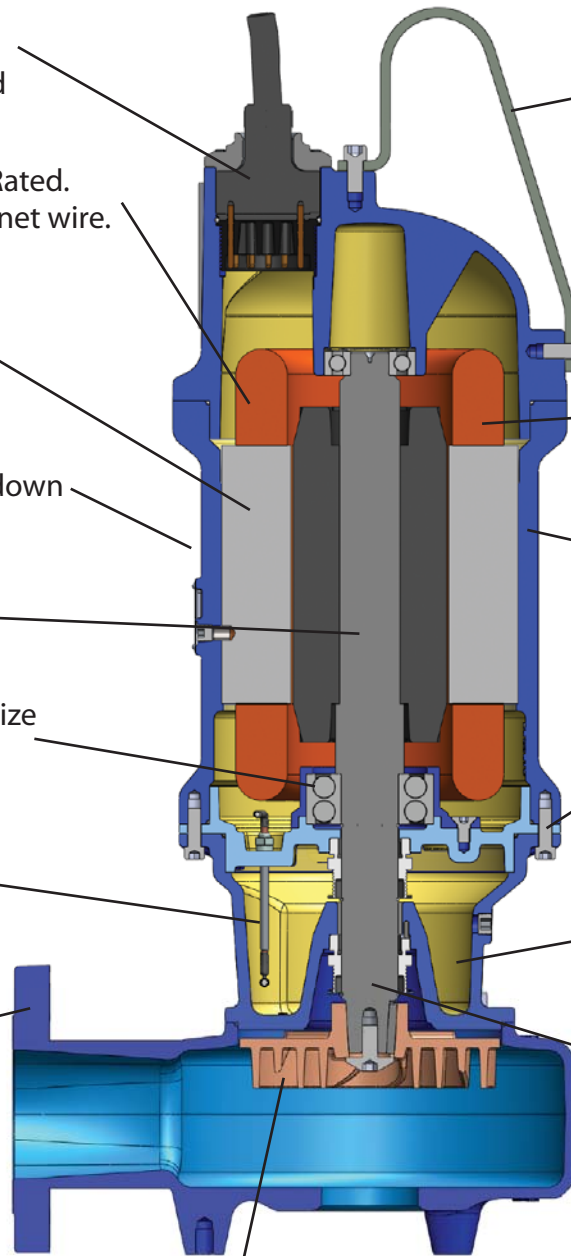

Large corrosion resistant stainless steel lifting bail

Optional FM Class I Group C&D Div 1 explosion-proof

Oil-filled motor for optimal motor cooling and maximum bearing life

2 coats of DuPont Corlar® epoxy coating

Stainless steel hardware for corrosion resistance

Large capacity seal chamber with moisture detector for cool-running seals

Tapered, keyed shaft reduces vibration for increased seal life

Optional bolt-on feet for free-standing installations (not shown)

Vortex Impeller ideal for pumping sewage with stringy solids

**CRANE**

A Crane Co. Company

**PUMPS & SYSTEMS**

**Crane Pumps & Systems**

420 Third Street  
Piqua, Ohio 45356  
(937) 778-8947  
Fax (937) 773-7157  
www.cranepumps.com

**Crane Pumps & Systems Canada**

83 West Drive  
Brampton, Ont. Canada L6T 2J6  
(905) 457-6223  
Fax (905) 457-2650

© Crane Pumps & Systems, Inc.  
A Crane Co. Company  
Printed in U.S.A.  
SHV (2/10)